

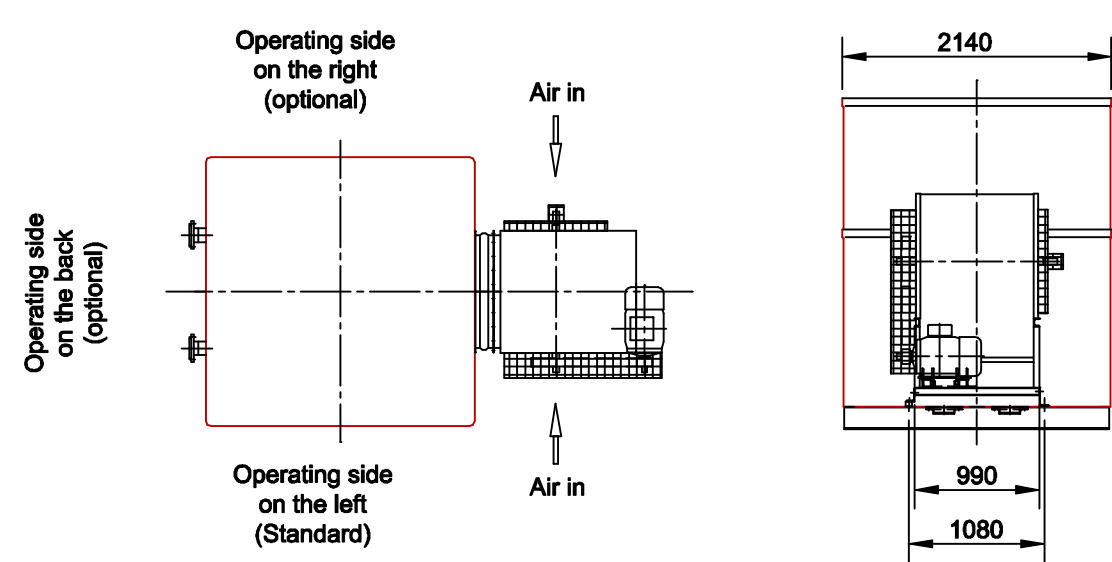

SUPERCHILL - SULZER Cooling Tower EWK-D 450

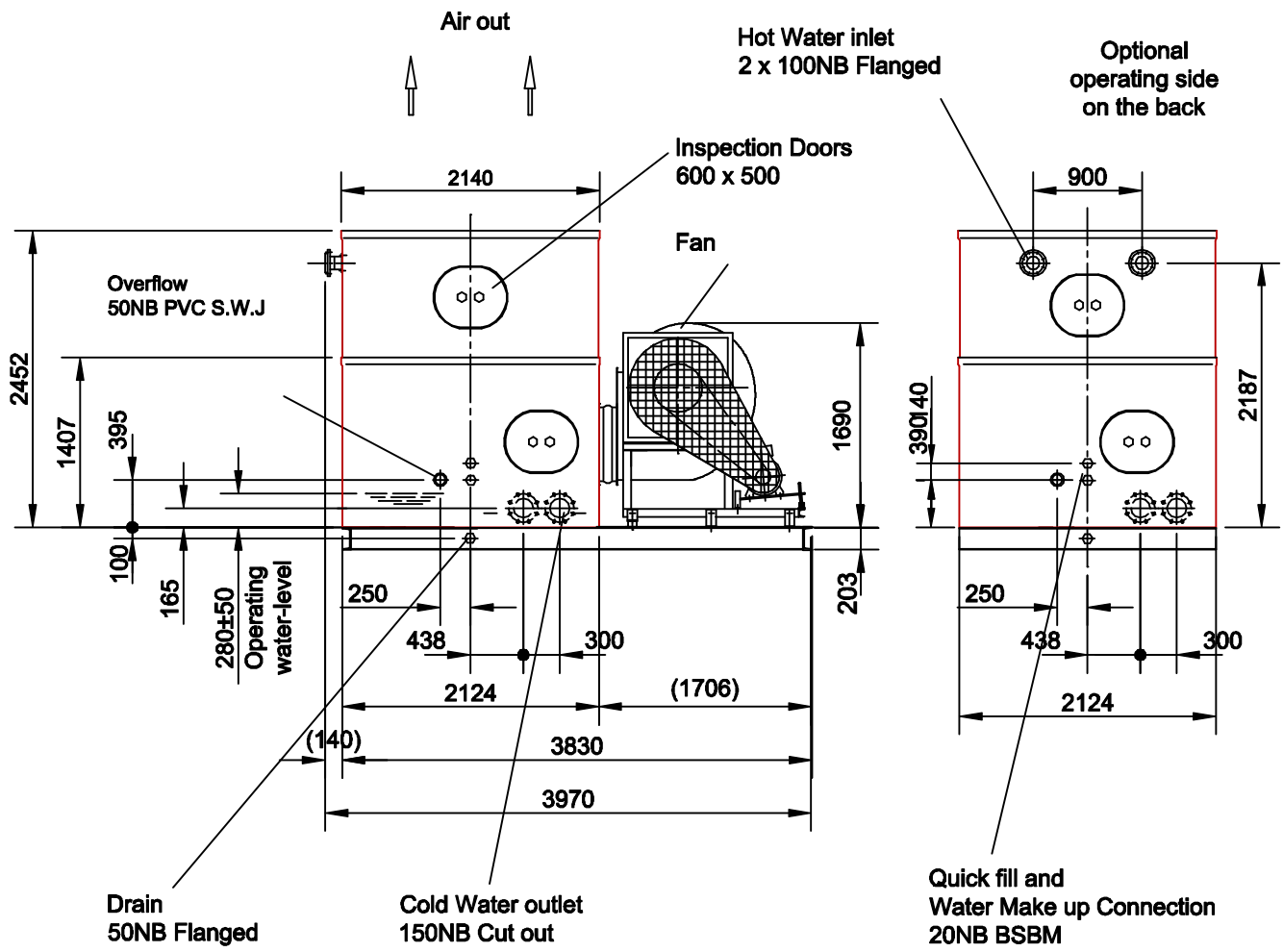

R 2.264 B Bl.1_D - 10.1999 / EWKD450 DIMENSION SHEET



	Weight in kg			Cold water outlet cut out TABLE "E"		
	Empty	Operating	Max	Water volume m³/h	35-70	71-135
Cooling tower total	900	3000	3600	Side outlet	1x150NB	2x150NB
				Optional Floor Outlet	1x150NB	1x200NB

All flanged connections and cut outs as per AS. 2129 Table "E"
 Tolerances of overall and connection dimensions ±10mm;