

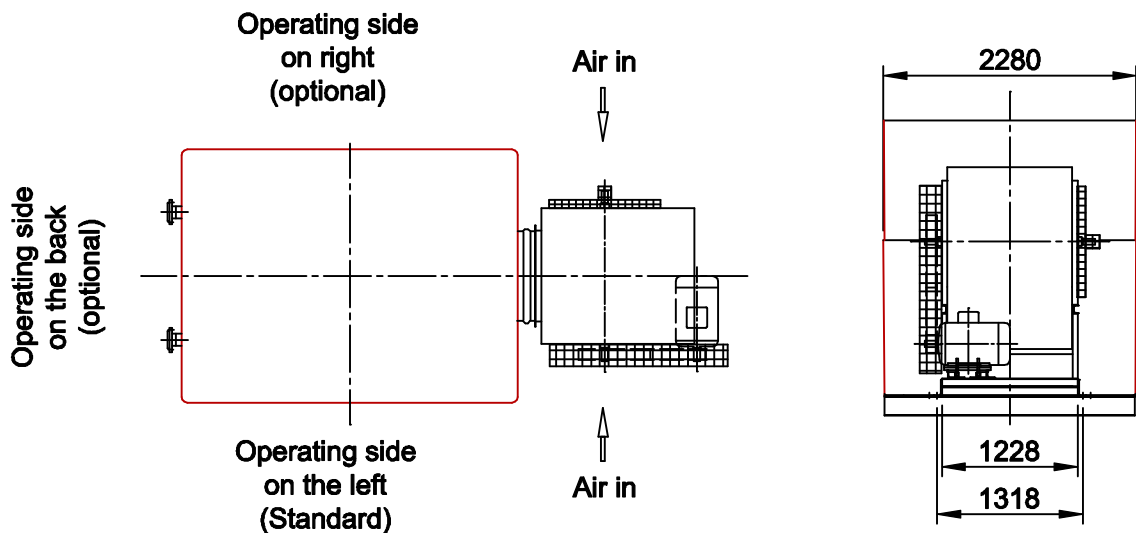

SUPERCHILL - SULZER Cooling Tower EWK-D 680

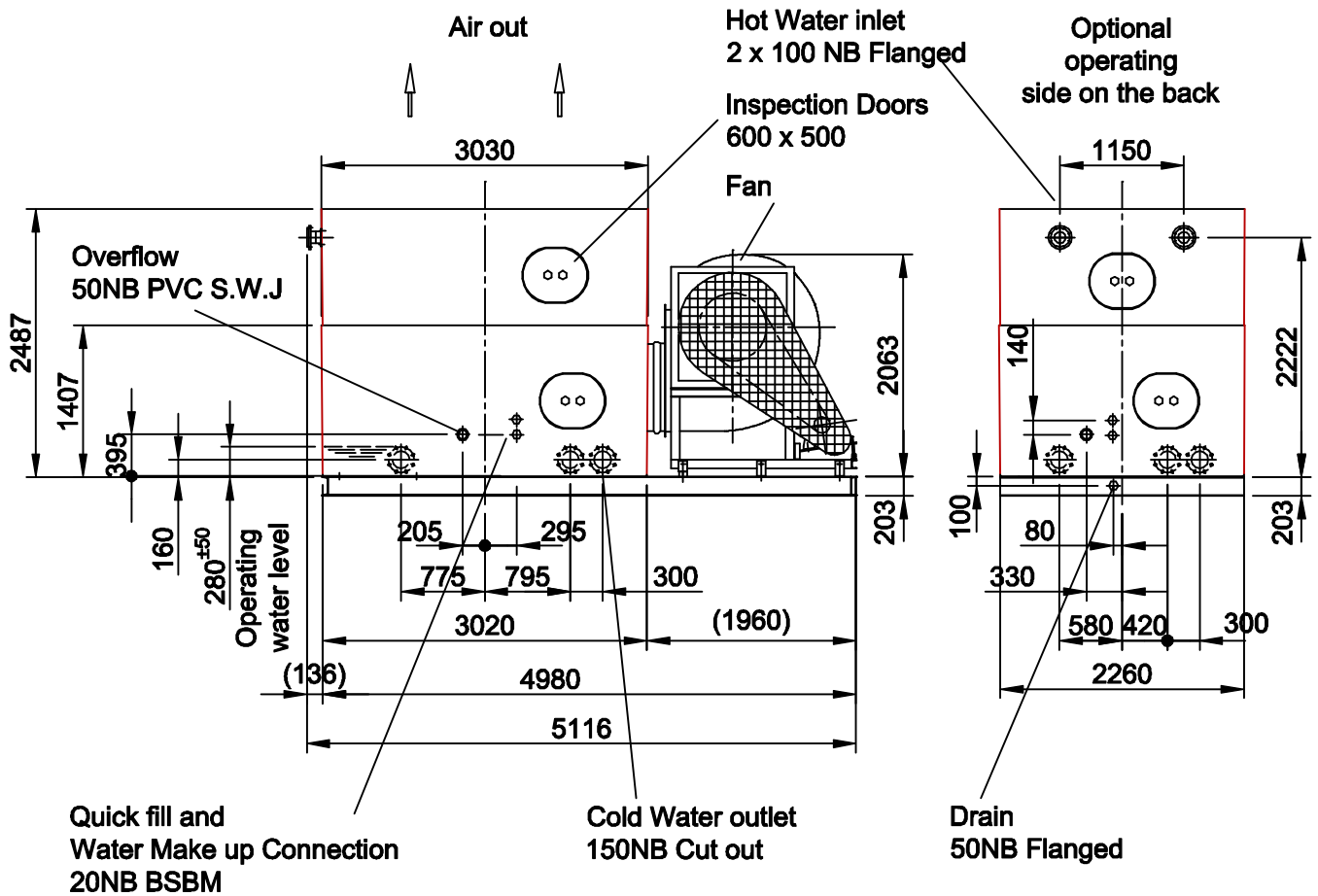

R 2.266 B Bl.1_D - 10.1999 / EWKD680 DIMENSION SHEET



	Weight in kg			Cold water outlet cut out Table "E" AS2129			
	Empty	Operating	Max	Water volume m³/h	60-80	81-160	161-200
Cooling tower total	1700	4300	5500	Side outlet	1x150NB	2x150NB	3x150NB
				Optional Floor outlet	1x200NB	1x250NB	1x250NB

All flanged connections and cut outs as per AS. 2129 Table "E"
 Tolerances of overall and connection dimensions ±10mm

SUPERCHILL AUSTRALIA PTY LTD
 256 Princes HWY Dandenong 3175
 Technical changes may occur without notification